

Arduino SPS

ArduinnoSPS Layout Documentation

Schematic

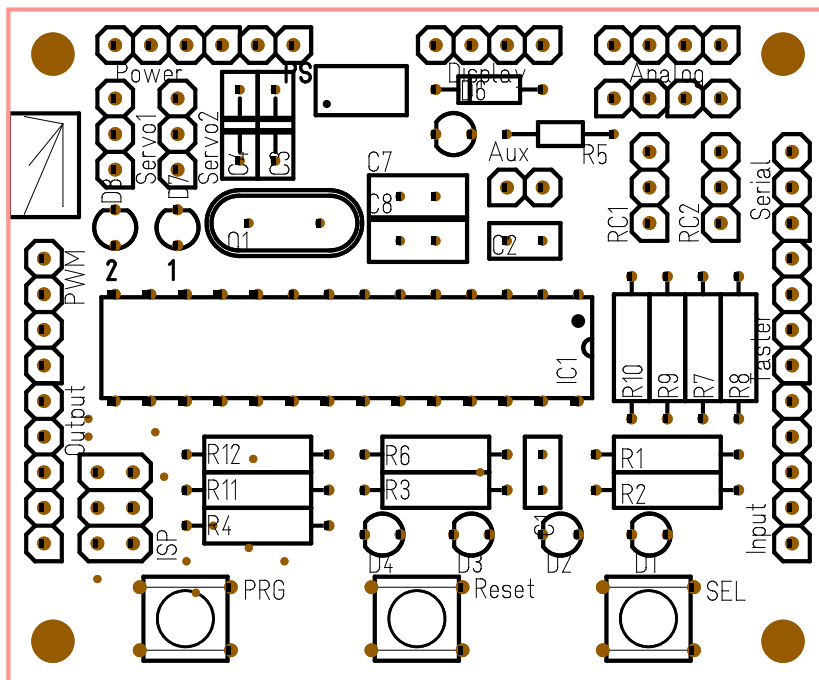
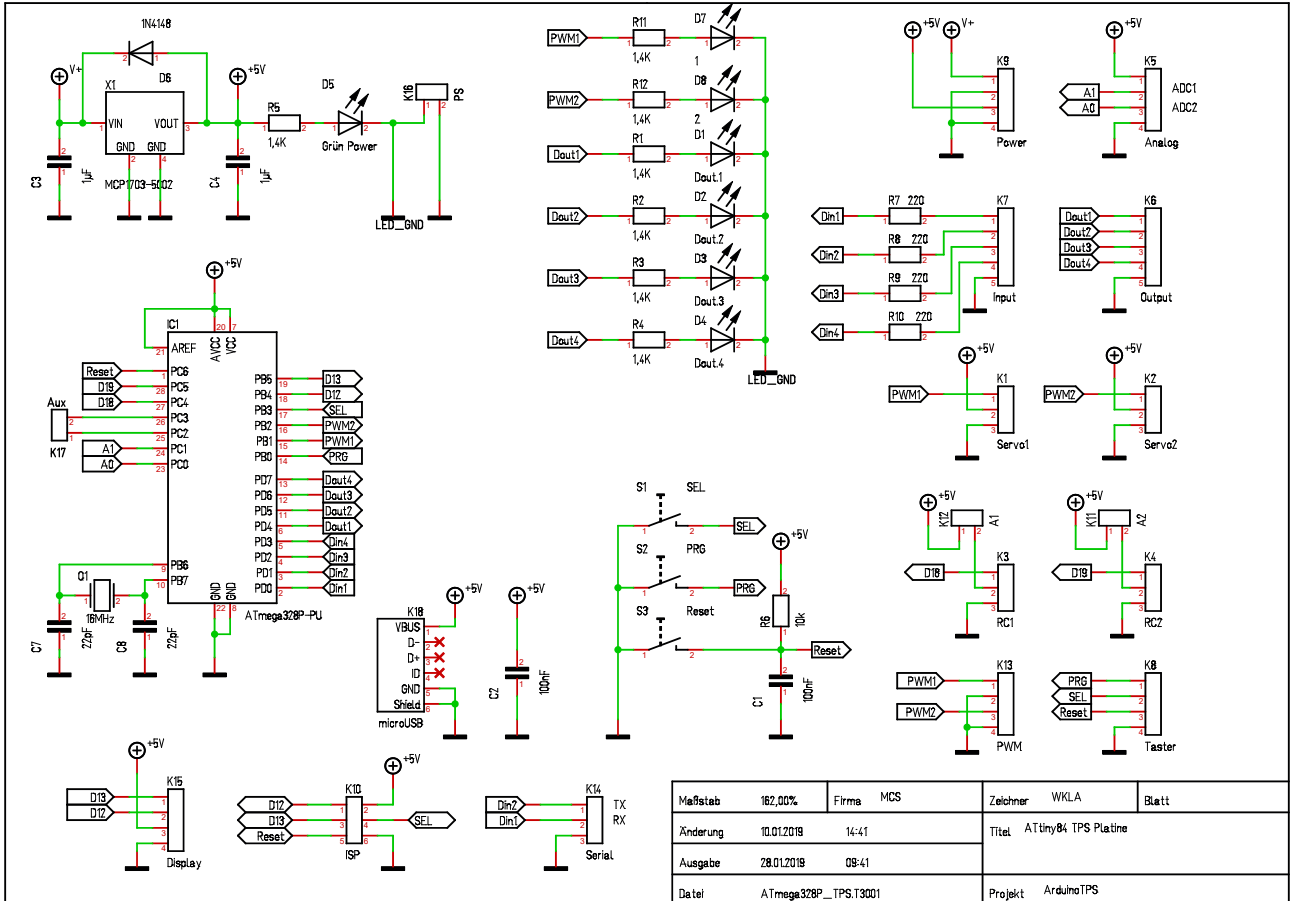

Connections

All connections to the board are described here.

Analog

The analog input provide access to A/D Convert 1 and 2. The pinout is

1	+5V
2	ADC1
3	ADC2
4	GND

Input

Standard TPS input section with 4 inputs protected by 220 Ohm resistors.

1	Din.1
2	Din.2
3	Din.3
4	Din.4
5	GND

Output

Standard TPS output section with 4 outputs parallel to the on board low current LEDs.

1	Dout.1
2	Dout.2
3	Dout.3
4	Dout.4
5	GND

PWM

PWM Outputs. Frequency 500Hz.

1	PWM1
2	GND
3	PWM2
4	GND

Power

Power connector to power up the TPS and to get some regulated power from the internal 5V source.
(max. 100mA)

- 1 PS, Power savings jumper, if not closed, all LEDs will be off
- 2 PS

- 1 V+in
- 2 GND
- 3 +5V
- 4 GND

Servo

There are 2 RC_Servo connections on this board.

- 1 PWM
- 2 +5V
- 3 GND

RC

There are two RC PWM Inputs for standard model receivers. The Pulse should be between 1ms and 2ms. The +5V pin can be powered via the internal source when the jumper A is closed. If the internal source is not wanted remove this jumper.

- 1 PWM
- 2 +5V (
- 3 GND

Switches (Taster)

The switches (or additional ones in parallel) can be placed outside as well.

- 1 PRG
- 2 SEL
- 3 Reset
- 4 GND

Serial

With the serial connector you can interact (or debug) with the mcu over a serial protocol. Mainly in TPS applications use to load new programs into the unit.

- 1 TX
- 2 RX
- 3 GND

Display

The display connector is used for a TM1637 like 7 segment display.

- 1 CLK
- 2 DATA
- 3 +5V
- 4 GND

ISP

The isp connector is used for a standart isp programmer.

- 1 MISO
- 2 +5V
- 3 SCK
- 4 MOSI
- 5 RESET
- 6 GND

BOM

Pos	Anzahl	Name	Wert	Gehäuse
1	2	C1,C2	100nF	2,54x5,08_RM2,54
2	2	C3,C4	1µF	C_RM5,08
3	2	C7,C8	22pF	3X7R2,54
4	1	D1	Dout.1	LED_3MM_GELB
5	1	D2	Dout.2	LED_3MM_GELB
6	1	D3	Dout.3	LED_3MM_GELB
7	1	D4	Dout.4	LED_3MM_GELB
8	1	D5	Grün Power	LED_3MM_GRÜN
9	1	D6	1N4148	DO35
10	1	D7	1	LED_3MM_GELB
11	1	D8	2	LED_3MM_GELB
12	1	IC1	ATmega328P-PU	DIL28_WB7,62_P2,54
13	1	K1	Servo1	Stiftleiste_1x03_G_2,54
14	1	K2	Servo2	Stiftleiste_1x03_G_2,54
15	1	K3	RC1	Stiftleiste_1x03_G_2,54
16	1	K4	RC2	Stiftleiste_1x03_G_2,54
17	1	K5	Analog	Stiftleiste_1x04_G_2,54
18	1	K6	Output	Stiftleiste_1x05_G_2,54
19	1	K7	Input	Stiftleiste_1x05_G_2,54
20	1	K8	Taster	Stiftleiste_1x04_G_2,54
21	1	K9	Power	Stiftleiste_1x04_G_2,54
22	1	K10	ISP	Stiftleiste_2x03_G_2,54
23	1	K11	A2	Stiftleiste_1x02_G_2,54
24	1	K12	A1	Stiftleiste_1x02_G_2,54
25	1	K13	PWM	Stiftleiste_1x04_G_2,54
26	1	K14	Serial	Stiftleiste_1x03_G_2,54
27	1	K15	Display	Stiftleiste_1x04_G_2,54
28	1	K16	PS	Stiftleiste_1x02_G_2,54
29	1	K17	Aux	Stiftleiste_1x02_G_2,54
30	1	K18	microUSB	JAE_DX4R005H91
31	1	Q1	16MHz	HC49/US
32	6	R1,R2,R3,R4,R11,R12	1,4K	0207_MET

Pos	Anzahl	Name	Wert	Gehäuse
33	1	R5	1,4K	0204_MET
34	1	R6	10k	0207_MET
35	4	R7,R8,R9,R10	220	0207_MET
36	1	S1	SEL	TASTER_KURZHUB
37	1	S2	PRG	TASTER_KURZHUB
38	1	S3	Reset	TASTER_KURZHUB
39	1	X1	MCP1703-5002	SOT223

If the LEDs are LowCurrent LEDs with 2mA, so the resistors are 1k4. If you are using normal LEDs with 20mA the value of the resistors is 150Ohm.